











Lampa oświetleniowa LED - *HIGH BAY* - 150W

ŚCIAMNIALNA 1-10V

Specyfikacja optoelektryczna

	Napięcie zasilania: 100-277V AC
	Zabezpieczenie przeciwprzepięciowe: 4 KV
	Częstotliwość 50-60Hz
	Moc: 150W
	Strumień świetlny: 19500LM
	Kąt świecenia: 90°
	-30°C - +50°C
	Waga: 5,5 Kg
	5 lat gwarancji
	CRI: ≥80
	Żywotność: 50.000h
	IP - 65
	Samsung 2835

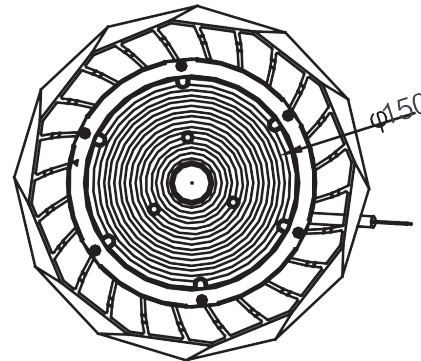
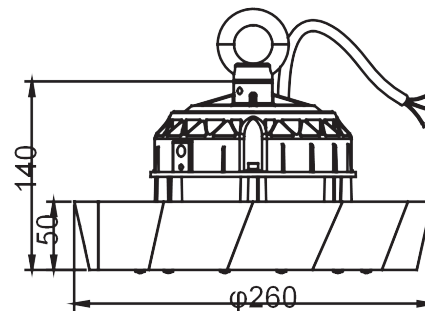
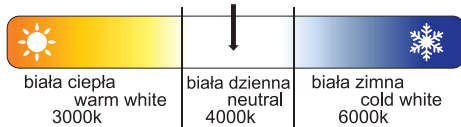

Zintegrowana lampa LED w obudowie IP65 do użytku wewnętrznego i zewnętrznego z zasilaczem ściemnianym 1-10V LIFUD

Zastosowanie:

- * Hale produkcyjne i magazynowe gdzie wysokość zawieszenia lamp to minimum 5m
- * Hale chłodnicze do temperatury max -30°C
- * Składy materiałów, place manewrowe
- * Elewacje zewnętrzne wysokich budynków
- * Boiska, korty
- * Sale gimnastyczne bez potrzeby używania dodatkowych osłon

